

INDUSTRIAL WASTEWATER PERMIT APPLICATION

Instructions: A separate application form must be filed for each point of discharge. Include additional information on attached sheets as necessary. Indicate by using N/A for the areas not applicable. Sections not marked will be considered as incomplete. Refer to the Instruction Packet.

FOR CITY USE	
Received Date:	_____
Fee: \$ _____	Receipt No: _____
Inspection District No.:	_____
IU No.:	_____
Permit No.:	_____
Category (Check One):	<input type="checkbox"/> SIU <input type="checkbox"/> LIU

Section 1. REASON FOR APPLYING AND PROPOSED POINT OF DISCHARGE

		PUBLIC SEWER	STORM DRAIN	PSDS	STATE WATERS	OTHER*
A. New or proposed Point of Discharge	<input type="checkbox"/>	<input type="checkbox"/>	<input type="checkbox"/>	<input type="checkbox"/>	<input type="checkbox"/>	<input type="checkbox"/>
B. Existing, but Unpermitted Point of Discharge	<input type="checkbox"/>					
C. New Ownership	<input type="checkbox"/>	<input type="checkbox"/>	<input type="checkbox"/>	<input type="checkbox"/>	<input type="checkbox"/>	<input type="checkbox"/>
Previous Company dba: _____						
Previous Permit Number: _____						
D. Permit Renewal	<input type="checkbox"/>	<input type="checkbox"/>	<input type="checkbox"/>	<input type="checkbox"/>	<input type="checkbox"/>	<input type="checkbox"/>
Permit Number: _____						
E. Permit Revoked	<input type="checkbox"/>	<input type="checkbox"/>	<input type="checkbox"/>	<input type="checkbox"/>	<input type="checkbox"/>	<input type="checkbox"/>
Permit Number: _____						
*If other, explain: _____						

Section 2. COMPANY INFORMATION

A. City of El Segundo Business Tax Registration No: _____

B. Legal Business Name: _____ Corporation Partnership Sole Proprietor

C. Facility Doing Business As (dba): _____

D. Names and Titles of Authorized Representatives:

Corporate Officers/Partners/other	Title
_____	_____
_____	_____
_____	_____

Attach copies of Partnership Agreement of Articles of Incorporation as applicable (See instructions)

E. Industrial User Location Address:

Address: _____
(Street) (City) (State) (Zip)

Facility Contact Person: _____ Phone No: _____ Ext.: _____

Title: _____

F. Billing Address:

Name: _____

Address: _____
(Street) (City) (State) (Zip)

Attention Name: _____ Phone No: _____ Ext.: _____

G. Mailing Address:

Name: _____

Address: _____
(Street) (City) (State) (Zip)

Attention Name: _____ Phone No.: _____ Ext.: _____

Company Name: _____

H. Property Owner Mailing Address:

Property Owner Name: _____

Address: _____
(Street) (City) (State) (Zip)

Attention Name: _____ Phone No.: _____

I. Number of Employees: _____ Number of Shifts: _____
Hours of Operation: _____ am/pm to _____ am/pm Days Per Week: S M T W Th F S

J. Average Operational/Production Days Per Year: _____ Average Discharge Days Per Year: _____

K. When did Operations Begin (Mo/Day/Yr)? _____ Has there been any construction since the beginning of operations that has modified or replaced the process or production equipment that caused the discharge of pollutants? YES NO
If YES, Explain: _____

L. Does the Business Hold Other City of El Segundo Industrial Wastewater Permits? YES NO
If YES, List the Industrial Wastewater Permit Number(s) and Expiration Date(s): (Attach additional sheets of paper if necessary)

Permit Number	Expiration Date	Permit Number	Expiration Date

Section 3. NATURE OF OPERATION(S)

A. List Raw Materials Used: _____

B. List Chemicals Used (Attach MSDS): _____

C. Describe Type of Business: _____

D. Describe Manufacturing or Service Activities Conducted:

Manufacturing or Service Activities Conducted	NAICS / SIC Code

E. Refer to Attachment A. Does your facility conduct processes subject to EPA federal regulations regardless of whether waster is being generated? YES NO If YES, List the Applicable Category(ies): _____

F. Describe Product(s) Produced/Manufactured:

Description of Product(s)	Production Past Calendar Year

Section 4. WASTEWATER FLOW

A. Indicate Source of Water Supply and Amount Consumed Per Year. Indicate as Estimated (E) or Measured (M):

Source	Consumption Gallons/Year	Water Meter Number(s)	E/M
<input type="checkbox"/> City of El Segundo			
<input type="checkbox"/> Private Well			
<input type="checkbox"/> Water from Raw Material or Other Means Explain: _____ _____ _____			
TOTAL			

B. Individual Wastewater Flows Generated in Gallons Per Operational/Production Day (GPD). Indicate Estimated (E) or Measured (M):

1. Process Wastewater Flows

Process Description List all wastewater generating operations	Average Flow (GPD)	Maximum Flow (GPD)	E/M	Type of Discharge (Batch, Continuous, None)	Avg. Discharge Days Per Month
TOTAL FLOW					

2. Other Wastewater Flows

Non-Process/Other Wastewater Flows	Average Flow (GPD)	Maximum Flow (GPD)	E/M	Type of Discharge (Batch, Continuous, None)	Avg. Discharge Days Per Month
Cooling Water (Non-Contact)					
Cooling Tower Bleed-Off (Non-Contact)					
Boiler Blowdown					
Sanitary					
Deionization Backwash					
Other					
TOTAL FLOW					

C. Non-Sewered Wastewater Flows and/or Water Losses in Gallons Per Operational/Production Day (GPD):
(Refer to Attachment B)

Non-Sewered Flows/Water Losses	Average Flow/Loss (GPD)	Maximum Flow/Loss (GPD)	E/M	Type of Discharge (Batch, Continuous, None)
Wastewater Discharged to Stormwater Drainage System (NPDES Permit No. _____)				
Water Losses Due to Evaporation				
Water Losses Due to Irrigation				
Water Losses Due to Product				
TOTAL FLOW				

D. Total Industrial Wastewater Flow in Gallons Per Operational/Production Day (GPD) Discharged to the City of El Segundo Sewer System: Average _____ Maximum _____

E. 1. Does the facility have discharge flow measurement device(s)? YES NO
 If YES, Indicate the Type/Location: Type: _____ Location: _____
 Type: _____ Location: _____

2. Does the discharge flow measurement device capture all industrial wastewater discharged from this facility?
 YES NO
 If NO, List wastewater flows not being captured:

F. Does the Facility Discharge Stormwater to the City of El Segundo Sewer System? YES NO
 If YES, Indicate the Daily Average and Maximum Discharge Rates (GPD):
 Average _____ Maximum _____

Section 5. OTHER WASTE DISPOSAL

List all hazardous wastes removed from the premises other than by the sewer system:

Type of Waste (Example: spent chemicals, organic solvents, treatment sludge)	EPA Waste I.D. Number	Amount Removed (lbs or gal) /mo

Section 6. POLLUTION PREVENTION

Does the facility employ pollution prevention techniques/practices? YES NO If YES, Please Describe:

Section 7. SPILL CONTROL

Has the facility developed a plan to prevent and control spills? YES NO If YES, Please Attach.

Section 8. ENVIRONMENTAL CONTROL PERMITS

List all environmental control permits held by or for the facility:

Descriptive Title of Permit	Permit Number	Issuing Agency	Expiration Date

Section 9. DIAGRAMS AND SCHEMATICS

- a. Provide on a separate sheet: (Refer to Attachment C)
 - 1) Site Plan
 - 2) Manufacturing Process Layout
 - 3) Tank Schedule
 - 4) Manufacturing Process Flow Diagram and Water Balance

- b. Provide a Pretreatment System Process Flow and Instrumentation diagram for any and all wastewater pretreatment utilized. Show treatment system location in relation to process flows on schematic drawing required by Question 9.A (Refer to Attachment C).

Section 10. SIGNATORY REQUIREMENT

I certify under penalty of law that I have personally examined and am familiar with the information in this application form and all attachments and that, based on my inquiry of those persons immediately responsible for obtaining the information contained in the application, I believe that the information is true, accurate and complete. I am aware that there are significant penalties for submitting false information, including the possibility of fine and/or imprisonment.

NAME – AUTHORIZED REPRESENTATIVE

SIGNATURE

OFFICIAL TITLE

DATE

FOR CITY USE ONLY				
Permit Type (Check One) LIU <input type="checkbox"/> SIU <input type="checkbox"/>	Inspector	Date	Sr. Inspector	Date

**INSTRUCTIONS FOR
INDUSTRIAL WASTEWATER PERMIT APPLICATION**

Please complete the enclosed application for each point of discharge.

Make check for \$340.00 payable to
City of El Segundo and return to the following address:

City of El Segundo
Public Works Department
350 Main Street, El Segundo, California 90245
Attn: Lifan Xu, P.E. City Engineer
If you have any questions, call (310) 524-2368

SECTION 1 – REASON FOR APPLYING

A.-E. Indicate the reason for applying for an Industrial Wastewater Permit and the proposed point of discharge as described below. Provide the current or former Industrial Wastewater Permit Number if the application is being filed due to a change in ownership, renewal or revocation. Provide the legal company name under the previous ownership if the application is filed due to a change in ownership.

POINTS OF DISCHARGE

Public Sewer - Any sewer, other than a house connection sewer, which has been constructed in a public street, alley, walk, or other public place, or in a sewer easement, and is part of the Publicly Owned Treatment Works (P.O.T.W.).

Storm Drain - All the property involved in the operation of the storm drainage collection and disposal system of the City of El Segundo, including conduits, natural or drains, channels and watercourse, together with appurtenances, pumping station and equipment.

PSDS (Private Sewage Disposal System) - Any septic tank, cesspool, seepage pit, leach field, or any other receptacle, or any combination thereof, which receives any wastewater not discharged into a public sewer.

State Waters - Saline water, streams, lakes, ponds, marshes, watercourse, waterways, well, springs, reservoirs, aquifers, irrigation systems and all other bodies or accumulations of water, surface or underground, natural or public or private, which are contained within, flow through, or border upon the State of California or any portion thereof.

SECTION 2 – COMPANY INFORMATION

A. **Definition of Business Tax Registration Certificate No. (BTRC):**

Account number from your business's City of El Segundo Tax Registration Certificate issued by the El Segundo City Clerk's Office.

B.-C. **Business Ownership Definitions And Documents Required:**

1 – Sole Proprietorship: A company, owned by one individual and no partners, which is not incorporated with the Secretary of State. Usually, such a business operates by obtaining a local business license and often uses a fictitious name (DBA). The local government agency (such as the city or county) issues both the business license, and a fictitious name statement. In this form of business, general liability rests with the owner. In the County of Los Angeles the City issues the Business Tax Registration Certificate (BTRC) and the County issues the fictitious name statement.

Example:

Legal Business name: John Doe (i.e. business owner's name)

DBA: John's Auto Body (i.e. business name)

Required Documents: - Fictitious name statement, if the business is operating under fictitious name (i.e. a name other than the business owner's)

2 – General Partnership: A company owned by two or more partners which is not incorporated with the Secretary Of State. Usually, such a business is governed by a partnership agreement naming the partners and establishing their relationships to one another. A general partnership usually obtains a business license and a fictitious name (DBA) in a manner similar to the sole proprietorship. In this form of business, the partners equally share in all liability of the business regardless of the percentage of their ownership.

Example:

Legal Business Name: John Doe & Mary Smith, (i.e. name of at least two partners)
DBA: Citrus Foods (i.e. business name)

Required Documents: -Partnership Agreement listing general partners.
 -Fictitious name statement

3- Limited Partnership: A company formed with two classes of owners -- Limited partners and general partners. Under the partnership agreement, the responsibilities of each class of partners are defined. Generally speaking, liability rests with the general partner(s), while the limited partners are merely investors and assume no liability. This type of partnership often obtains a business license and a fictitious name (DBA) in a manner similar to a general partnership.

Example:

Legal Business Name: John Doe (i.e. name of at least one General Partner)
DBA: International Jewelry Center (i.e. business name)

Note: John Doe must be a General Partner. Do not use names of Limited Partners.

Required Documents: -Partnership Agreement listing general partners.
 -Fictitious name statement

4- Corporations: A company formed by one or more individuals and incorporated through the Secretary of State. This type of business is usually governed by the articles of incorporation which require the company to be controlled by the plurality of shareholders. The shareholders elect a board of directors which is responsible for the operations of the company. A corporation is a legal "person". This means that the entity can and does assume liability like an individual. This arrangement relieves the owners of personal liability under the law. Similar to other forms of businesses, corporations obtain business licenses and can assume fictitious names (DBA).

Example:

Legal Business Name: ABC Inc. (i.e. name of Corporation)
DBA: ABC Markets (i.e. business name)

Required Documents : -Copy of the Articles of Incorporation accepted and stamped by the Secretary of State
 -Fictitious name statement
 -List of Officers and Directors
 -Agent for service of process

D. An **authorized representative** of a discharger shall mean (a) a President, secretary, treasurer, or vice-president in charge of a principal business function, or any other person who performs similar policy- or decision-making functions, if the discharger is a corporation; (b) the manager of one or more manufacturing, production, or operation facilities employing more than 250 persons or having gross annual sales or expenditures exceeding \$25 million (in second-quarter 1980 dollars), if the discharger is a corporation and authority to sign documents has been assigned or delegated to the manager in accordance with corporate procedures; (c) a general partner or proprietor if the discharger is a partnership or proprietorship, respectively; (d) a principal executive officer or director having responsibility for the overall operation of the discharging facility or a ranking elected official if the discharger is a governmental entity, charitable organization or other such unincorporated entity; or (e) a representative authorized in writing by the individual designated above, if the authorization is submitted to the Director and specifies an individual or a position having responsibility for the overall operation of the facility which contributes wastewater to the Publicly Owned Treatment Works (P.O.T.W.), storm drain system, or the Water of the State. This includes the position of plant manager, a position of equivalent responsibility, or an individual having overall responsibility for environmental matters for the company. If an authorization under paragraph (e) is no longer accurate because a different individual or position has the responsibility for the overall operation of the facility, a new authorization satisfying the requirements of paragraph (e) of this section must be submitted to the Director prior to or together with any reports to be signed by such person.

E. Industrial User Location

F. Industrial User Billing Address

G. Permittee Mailing Address

H. Property Owner Mailing Address

SECTION 3 – NATURE OF OPERATION(S)

- A.- B. Provide a listing of all primary raw materials and chemicals used in the facility's operations. Avoid use of trade names of chemicals. If trade names are used, provide information regarding the active ingredients. **Material Safety Data Sheets must be provided for all chemicals used in the facility.**
- C. - E. Describe the type of business and the manufacturing or service activities conducted. Indicate the 6-digit North American Industry Classification System (NAICS) code or the 4-digit Standard Industrial Classification (SIC) code for each activity. For a detailed description of the NAICS code, refer to the latest version of the North American Industry Classification System Manual. For a detailed description of the SIC code, refer to the Standard Industrial Classification Manual. For any questions regarding either the NAICS or SIC codes please contact this office. Refer to Attachment A and identify, if applicable, the industrial category your facility may be subject to regardless of whether the wastewater is being generated.
- F. Describe the products manufactured and indicate the production rate for each product for the past calendar year (i.e., lbs. or sq. ft. of (product name)/year).

SECTION 4 – WASTEWATER FLOW

- A. Indicate source of water supply, water meter numbers(s) and provide gallons of water consumed per year. Attach copies of most recent 12 consecutive months of water bills, meter readings and/or other records. If records are not available, provide an estimated 1 year water consumption. Indicate if consumption amount is estimated or measured.
- B. Provide a breakdown of the sources of the total plant process and non-process wastewater flows to the sanitary sewer. Process wastewater is any water which, during manufacturing or processing, comes into direct contact with or results from the production or use of any raw material, intermediate product, finished product, by-product, or waste product. Contact cooling water will be considered as process wastewater. **For estimated flows, calculations and assumptions must be attached to justify the flows provided.** Indicate if flow is estimated or measured, the type of discharge (batch, continuous or none) and average discharge days per month for each source generating wastewater. Sanitary flow may be estimated by allowing 15 gallons per employee per day.
- C. Provide a breakdown of the non-sewered flows/water losses. **For estimated flows, calculations and assumptions must be attached to justify the flows provided.** Indicate if flow is estimated or measured and the type of discharge (batch, continuous or none) for each source generating wastewater. Refer to Attachment B for guidance in estimating non-sewered flow/water losses.
- D. Provide the total industrial wastewater flow (average and maximum) to the sanitary sewer. If accurate flow measurements are unavailable, provide the best estimate. **Attach the most recent water bills covering the last 12 consecutive months.** Wastewater flow, based on operational day and calendar day methods, respectively, may be estimated by using the following formulas:

1. Operational Day Method

$$\begin{array}{l} \text{Industrial} \quad \text{Gal of water consumed per year (4.A)} \\ \text{Wastewater} = \frac{\text{-----}}{\text{Operational/Production days per year (2.G)}} - \text{Daily Sanitary Flow (4.B.2.)} - \text{Daily Water Losses (4.C.)} \\ \text{Flow} \end{array}$$

Note: The information in the parenthesis is the corresponding section of the permit application where the values may be obtained.

- E. Self Explanatory
- F. Self Explanatory

SECTION 5 – OTHER WASTE DISPOSAL

List the hazardous wastes and other spent material removed from the premises by other than the sewer system. Provide the corresponding EPA Hazardous Waste Number for each type of waste removed. Determine the average monthly volume of waste removed. (Note: Refer to the Uniform Hazardous Waste Manifest - DHS 8022A, when appropriate).

SECTION 6 – POLLUTION PREVENTION

If the facility employs waste minimization techniques or procedures, describe the techniques or practices used. Waste minimization techniques can be grouped into four major categories: inventory management and improved operation, modification of equipment, production process changes, and recycling and reuse. Example techniques include, but are not limited to product substitution/conservation, material purification/substitution, process changes, material handling improvements, wastestream segregation, management practices, maintenance programs, closed-loop systems, and recycle onsite/offsite for reuse.

SECTION 7 – SPILL CONTROL

Indicate if the facility has a spill control and prevention plan. The plan must contain at a minimum the following elements: (a) Description of discharge practices; (b) Description of stored chemicals; (c) Any procedures for promptly notifying the Public Works Department of spills; (d) Any procedures to prevent accidental spills, including maintenance of storage areas, handling and transfer of materials, loading and unloading operations, and control of plant site run-off; (e) Any measures for building containment structures or equipment; (f) Any measures for controlling toxic organics; (f) Any procedures and equipment for emergency response; and (g) Any follow-up practices to limit the damage suffered by the treatment plant or the environment.

SECTION 8 – ENVIRONMENTAL CONTROL PERMITS

List all environmental control permits held by or for the facility. Examples of agencies issuing environmental control permits include, but are not limited to the following: U.S. EPA, Regional Water Quality Control Board, State Water Resources Control Board, Department of Health Services, Air Quality Management District and City of El Segundo Fire Department.

SECTION 9 – DIAGRAMS AND SCHEMATICS

A.- B. In order to provide the Public Works Department a complete understanding of the facility's processes, pretreatment system and sampling points, the discharger is required to submit a schematic of each process and a schematic of wastewater flows. Refer to Figures 1-4 for example schematics. Be sure to indicate on the flow or process schematic where samples are taken.

SECTION 10 – SIGNATORY REQUIREMENT

This application and any required reports must be signed by an authorized representative. *(See Section 2D of Instructions)*

PLEASE MAKE A COPY OF THE COMPLETED APPLICATION AND SUPPORTING DOCUMENTATION FOR YOUR RECORDS PRIOR TO SUBMITTAL TO THE PUBLIC WORKS DEPARTMENT.

ATTACHMENT A
EPA CATEGORICAL INDUSTRIES

1. **Aluminum Forming (40 CFR 467):** EPA defines aluminum forming as the "deformation of aluminum or aluminum alloys into specific shapes by hot or cold working such as rolling, extrusion, forging, and drawing." Also included within this category are the associated operations of casting, heat treating and surface treatment that are part of the forming process.
2. **Asbestos Manufacturing (40 CFR 427):** This category regulates discharges resulting from the manufacture of asbestos and asbestos products including: asbestos cement pipe, asbestos cement sheet, asbestos paper, asbestos millboard, asbestos roofing products, asbestos floor tile, and cooling or impregnating asbestos textile.
3. **Battery Manufacturing (40 CFR 461):** Battery manufacturing encompasses the production of modular electric power sources where all or part of the fuel is contained within the unit and electric power is generated directly from a chemical reaction rather than indirectly through a heat cycle engine.
4. **Coil Coating, Phase I (40 CFR 465):** EPA regulations state that "Coil coating consists of that sequence of combination of steps or operations which clean, surface or conversion coat, and apply an organic (paint) coating to a long thin strip or coil of metal." The metal basis material includes steel, galvanized material or aluminum.
5. **Coil Coating, Phase II - Can Making Subcategory (40 CFR 465):** This classification is a subcategory of coil coating and has been defined to be "the process or processes used to manufacture a can from a base metal, including aluminum and steel." This category applies to seamless cans only.
6. **Copper Forming (40 CFR 468):** EPA defines copper forming to include "the five basic processes used to form copper or copper alloys: hot rolling, cold rolling, extrusion, drawing, and forging."
7. **Electrical and Electronic Components, Phase I (40 CFR 469):** This category consists of all operations associated with the manufacturing of semiconductors and electronic crystals except for sputtering, electroplating, and vapor plating operations.
8. **Electrical and Electronic Components, Phase II (40 CFR 469):** This category consists of all operations associated with the manufacturing of semiconductors, electronic crystals, cathode ray tubes and luminescent materials.
9. **Electroplating (40 CFR 413):** This category consists of electroplating, anodizing, coating (chromating, phosphating, and immersion plating), electroless plating, chemical etching and milling, and the manufacturing of printed circuit boards. This category applies to job shops only in existence prior to August 31, 1982.
10. **Fertilizer Manufacturing (40 CFR 418):** This category applies to discharges from the manufacture of sulfuric acid, nitric acid (in concentrations up to 68%), ammonium sulfate by the synthetic process or by coke oven byproduct recovery, and mixed and blend fertilizers. It is only applicable to sulfuric and nitric acid manufacturing processes that have been constructed or significantly modified since December 7, 1973 and ammonium sulfate and mixed and blend fertilizer manufacturing processes that have been constructed or significantly modified since October 7, 1974.
11. **Glass Manufacturing (40 CFR 426):** This category consists of manufacturers of glass containers, television picture tubes, incandescent lamp envelopes, and hand pressed and blown glass. Only facilities which have been constructed or significantly modified since August 21, 1974 are regulated.
12. **Ink Formulating (40 CFR 447):** This category applies to discharges resulting from the formulation of oil-base ink where the tank washing system uses solvents. It is only applicable to processes that have been constructed or significantly modified since February 26, 1975.
13. **Iron and Steel (40 CFR 420):** This category covers steel works, blast furnaces (including coke ovens), rolling mills, electrometallurgical products, steel wire drawing and facilities which produce steel nails and pikes, and steel pipes and tubes. This category does not include coil coating operations.
14. **Leather Tanning and Finishing (40 CFR 425):** This category consists of the tanning, currying, and finishing of hides and skins into leather.
15. **Metal Finishing (40 CFR 433):** This category consists of electroplating, anodizing, coating (chromating, phosphating and metal coloring), electroless plating, chemical etching and milling, and the manufacturing of printed circuit boards. This category applies to captive ships (owns 50 percent or more of the surface area finished), and all new source electroplating and metal finishing operations (those which began construction after August 31, 1982).

ATTACHMENT A
(Continuation)

16. **Metal Molding and Casting (40 CFR 464):** This category consists of the pouring or injection of molten metal into a mold with the cavity of the mold representing, within close tolerances, the dimensions of the final product. This category includes aluminum, copper, ferrous, and zinc casting.
17. **Nonferrous Metals Forming and Metal Powders (40 CFR 471):** This category consists of the deformations of a metal (other than iron) or metal alloy (other than iron as the major component by weight) into specific shapes by hot or cold rolling, extruding, drawing, forging, swagging, cladding and tube reducing.
18. **Nonferrous Metals Manufacturing, Phase I and II (40 CFR 421):** This category applies to facilities producing primary metals from ore concentrates and recovering secondary metals from recycle wastes.
19. **Organic Chemicals, Plastics, and Synthetic Fibers (40 CFR 414):** This category consists of the manufacturing of organic chemicals, plastics and synthetic fibers.
20. **Paint Formulating (40 CFR 446):** This category applies to discharges resulting from the formulation of oil-base paint where the tank cleaning is performed using solvents. It is only applicable to processes that have been constructed or significantly modified since February 26, 1975.
21. **Pesticide Chemical Manufacturing (40 CFR 455):** This category consist of manufacturers of organic pesticide chemical, metallo organic pesticide chemical and facilities that are engaged in pesticide chemical formulating and packaging.
22. **Petroleum Refining (40 CFR 419):** This category includes operations which produce gasoline, kerosene, distillate fuel oils, residual fuel oils and lubricants, through fractionation or straight distillation of crude oil, redistillation of unfinished petroleum derivatives, cracking or other processes.
23. **Pharmaceutical Manufacturing (40 CFR 439):** This category includes pharmaceutical manufacturing facilities which may use fermentation, extraction, chemical synthesis, mixing/compounding and formulation, or may conduct research.
24. **Porcelain Enameling (40 CFR 466):** EPA defines porcelain enameling as "that sequence or combination of steps or operations which prepare the metal surface and apply a porcelain or fused silicate coating to the metal basis material." The metal basis material includes steel, cast iron, aluminum and copper.
25. **Pulp, Paper, and Paperboard and the Builders' Paper and Board Mills (40 CFR 430 and 431):** This category includes pulp mills, paper mills, paperboard mills, and building paper and building board mills.
26. **Rubber Manufacturing (40 CFR 428):** This category consists of manufacturers that reclaim rubber or mold, extrude, or fabricate rubber products, including latex products. It is only applicable to facilities that have been constructed or significantly modified since August 23, 1974.
27. **Soap and Detergent Manufacturing (40 CFR 417):** This category consists of facilities which blend or package liquid detergents or manufacture dry detergents by spray drying, drum drying, or dry blending. Only facilities which have been constructed or significantly modified since December 26, 1973 are regulated.
28. **Steam Electric Power Generation (40 CFR 423):** This category is composed of facilities that are engaged in the generation of electricity for distribution and sale, and use either fossil-type fuel (coal, oil, or gas) or nuclear fuel in conjunction with a thermal cycle that has a steam/water thermodynamic medium.
29. **Textile Mills (40 CFR 410):** This category applies to the fiber preparation and manufacturing/processing parts of the textile industry.
30. **Timber Products (40 CFR 429):** This category consists of a diverse group of manufacturing plants whose primary raw material is wood and whose products range from finished products to hardboard and preserved wood.

ATTACHMENT B
ESTIMATING NON-SEWERED FLOWS/WATER LOSSES

I. EVAPORATIVE LOSSES

A. Cooling Tower

Capacity, (Tonnage)	x	Hours of operation per day, (hr/day) ¹	x	Load ²	x	1.37 ³	=	Gallons Evaporated Per Day
	x		x		x	1.37	=	
	x		x		x	1.37	=	
							Total	

¹Time heat load is being applied

²Load = 0.50 to 0.80

³1.37 = Gallons evaporated per hour per ton = (12000 BTU/ton-hr) / (8760 BTU/gal)

B. Boiler

Capacity, (Horsepower)	x	Hours of operation per day, (hr/day) ⁴	x	Load ⁵	x	% Evaporation ⁶	1.37 ⁷	=	Gallons Evaporated Per Day
	x		x		x		1.37	=	
	x		x		x		1.37	=	
								Total	

⁴Time heat load is being applied

⁵Load = 0.50 to 0.80

⁶% Evaporation = (100 - % Condensate returned) / 100

⁷3.82 = Gallons evaporated per hour per horsepower = (33446 BTU/HP-hr) / (8760 BTU/gal)

C. Other Evaporative Losses – Assumptions and calculations must be provided to justify the losses.

II. WATER LOSSES

A. Wastewater Discharged to Stormwater Drainage System – Refer to NPDES Permit

B. Irrigation Losses

Square Feet of Land Irrigated	x	.00368 ⁸	x	25 ⁹	=	Irrigation Use (gallons per day)
	x	.00368	x	25	=	

⁸City-Wide Average Billing Units per sq. ft. based on City Water Conservation Appeals Procedure

⁹1 Billing Unit (30 day period) equals 25 gallons per day

C. Product Losses – Assumptions and calculations must be provided to justify the losses. Annual Production and water requirements for each product must be provided.

ATTACHMENT C
DIAGRAMS AND SCHEMATICS

I. MANUFACTURING PROCESS INFORMATION

A. Site Plan

The Site Plan (Figure 1) shall provide information to identify the building location relative to the streets and surrounding areas and provide information on the general piping connections for water and sewer. The drawings shall be drawn to scale and include the following:

1. North arrow, scale size, name of company and address, drawing name and number, date drawn and date revised, and who drew and approved the drawing.
2. The building location with respect to streets.
3. The overall building dimensions.
4. The wet process locations and area dimensions.
5. All floor drains, sewer connections and storm drains.
6. Above-ground and below-ground main waste/wastewater piping, drain and pipe sizes, sewer connection to the city's sewer.
7. All main incoming water piping, water meter location(s), and water meter number(s).

B. Manufacturing Process Layout

The Manufacturing Process Layout (Figure 2) shall provide information regarding location of each manufacturing equipment in the wet process area, including process/storage tanks, water and wastewater lines, and floor drains. The drawing shall be drawn to scale and include the following:

1. North arrow, scale size, name of company and address, drawing name and number, date drawn and date revised, and who drew and approved the drawing.
2. Lay-out of all process tanks and equipment. Each process tank/equipment must be properly identified (preferably with a number or letter) with its corresponding name.
3. All above-ground and below-ground incoming water piping connection to process tanks/equipment.
4. All floor drains.
5. Location of the representative sampling point.

Note: Do not include manufacturing process layout for areas that do not involve wet processing, but identify the area by name (e.g. drilling area, office).

C. Tank Schedule

The permittee must complete and submit the enclosed **Tank Schedule Form A** to describe the contents, dimensions and specifications of all tanks used in the process or pretreatment areas. Each tank must be numbered or labeled to correspond with the tanks shown on the manufacturing process layout. For each identified flow-through/continuous flow rinse tanks, make-up water flow rates and discharge flow rates in gallons per minute (gpm) must be provided. Attach additional sheets if necessary.

D. Manufacturing Process Flow Diagram and Water Balance

The purpose of this diagram is to identify the sources of pollutants by tracking down the transfer of contaminants from one process to another. This diagram (Figure 3) will also provide information on the average volume of waste-water generated per **operational/production day** by the various manufacturing processes.

The flow diagram shall consist of flow charts for each manufacturing process showing flow of raw material and the generation of wastewater through the different processes.

II. EXISTING WASTEWATER PRETREATMENT SYSTEM

A. Existing Pretreatment System Location Drawings and Layout

The Pretreatment System Location Drawing shall provide information to identify the location of the pretreatment system relative to the manufacturing process, sewer lines, and the wastewater sampling point. This drawing may be incorporated into the Site Plan as described in Attachment C.(I).

The Pretreatment System Layout Drawing shall be drawn to scale and shall provide information regarding location of each pretreatment equipment, including pretreatment and chemical feed tanks, treatment units, and instrumentation. The following shall be included:

1. Lay-out of all pretreatment tanks and equipment. Each pretreatment system tank/equipment must be properly identified with its corresponding name.
2. All above-ground and below-ground wastewater piping connections from the manufacturing process tanks and equipment to the pretreatment system shall be shown. Also all piping from the pretreatment system to the sampling point and sewer system shall be shown.
3. Location and dimensions of representative sampling point.

B. Existing Pretreatment System Process Flow and Instrumentation Diagram

The Pretreatment System Process Flow and Instrumentation Diagram (Figure 4) shall provide information regarding all wastewater treatment processes. The purpose of this diagram is to show how wastewater treatment is accomplished through the different pieces of equipment. This process flow diagram shall:

1. Show all pretreatment equipment including but not limited to pumps, mixers, control valves, equalization tank, pH adjustment tank, clarifier, filter, electro-recovery system, ion exchange system, and filter press.
2. Show all the process control systems including the controlled element (pH, ORP, flow, level), controllers, recorders, totalizer, and the signal to the device that is controlled (metering pump, control valve, pump motor).

NOTE: The plans submitted must have sufficient quality, to reproduce clearly. All drawings must have good contrast, clear background and legible labeling. The drawings shall have minimum dimensions of 8½ inches by 11 inches and maximum dimensions of 11 inches by 17 inches.

FIGURE 1 - EXAMPLE SITE PLAN

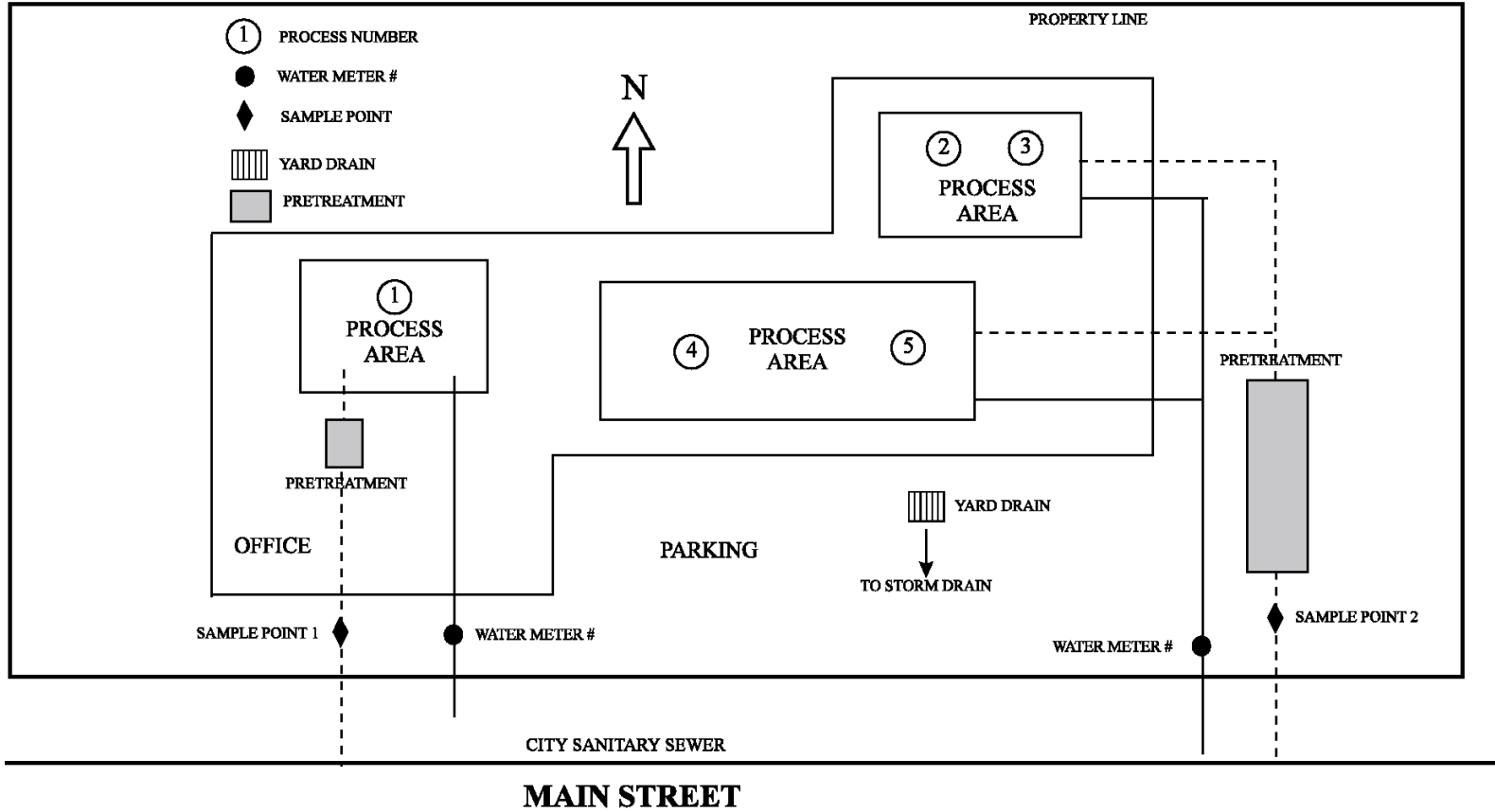



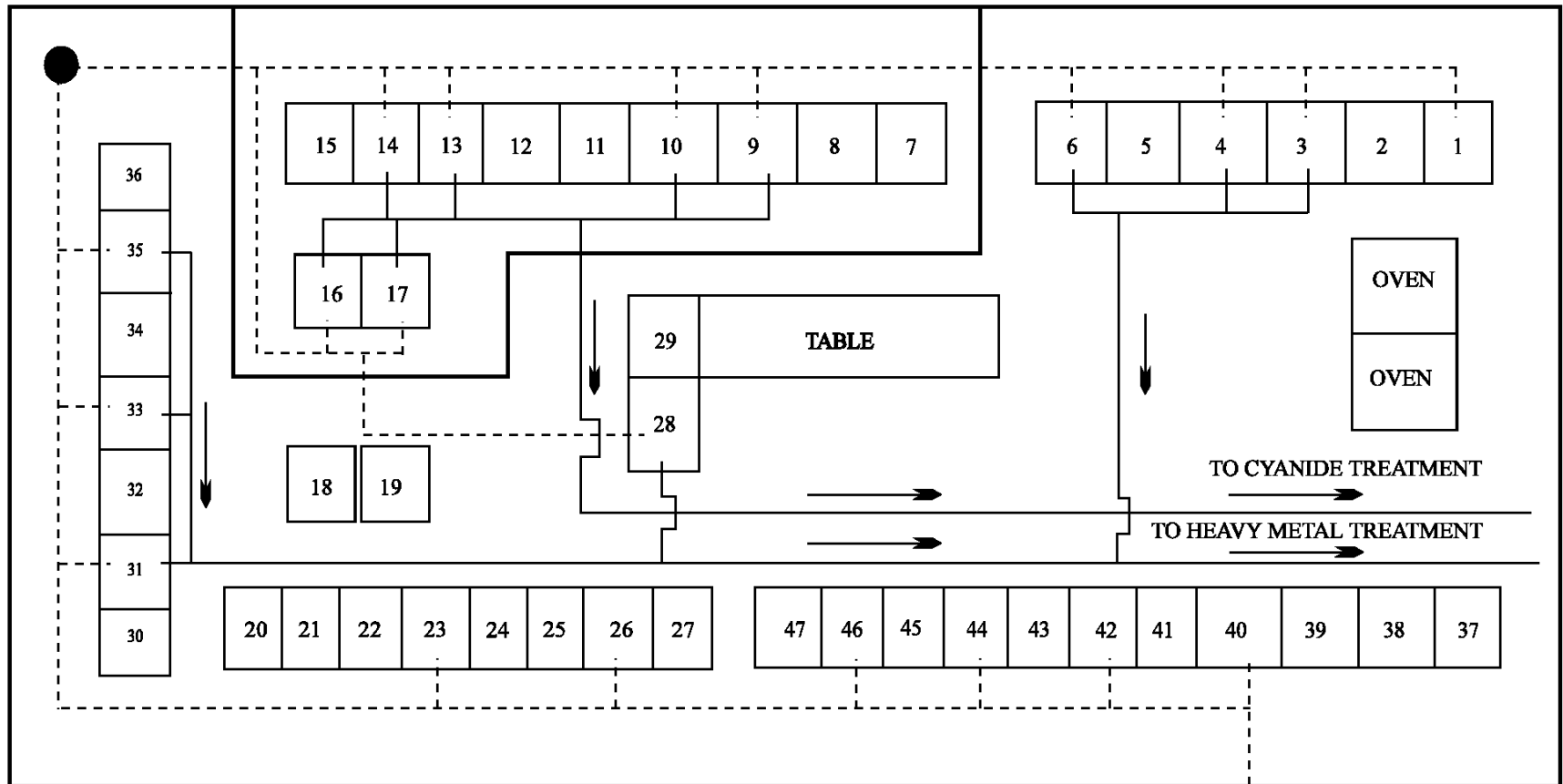

Site Plan	
XYZ COMPANY 12345 MAIN ST., EL SEGUNDO, CA 90245	
DRAWN BY: _____	DATE: _____
APPROVED BY: _____	DATE: _____

FIGURE 2 - EXAMPLE MANUFACTURING PROCESS LAYOUT



LEGEND:

-  MAIN WATER SOURCE
-  SPILL CONTAINMENT
-  WATER SUPPLY LINE
-  WASTEWATER LINE

TMAFIGZ.CDR



MANUFACTURING PROCESS LAYOUT Plating Process No. 1 – Building A	
XYZ COMPANY 12345 MAIN ST., EL SEGUNDO, CA 90245	
DRAWN BY: _____	DATE: _____
APPROVED BY: _____	DATE: _____

**FIGURE 3
EXAMPLE MANUFACTURING PROCESS FLOW DIAGRAM
AND WATER BALANCE**

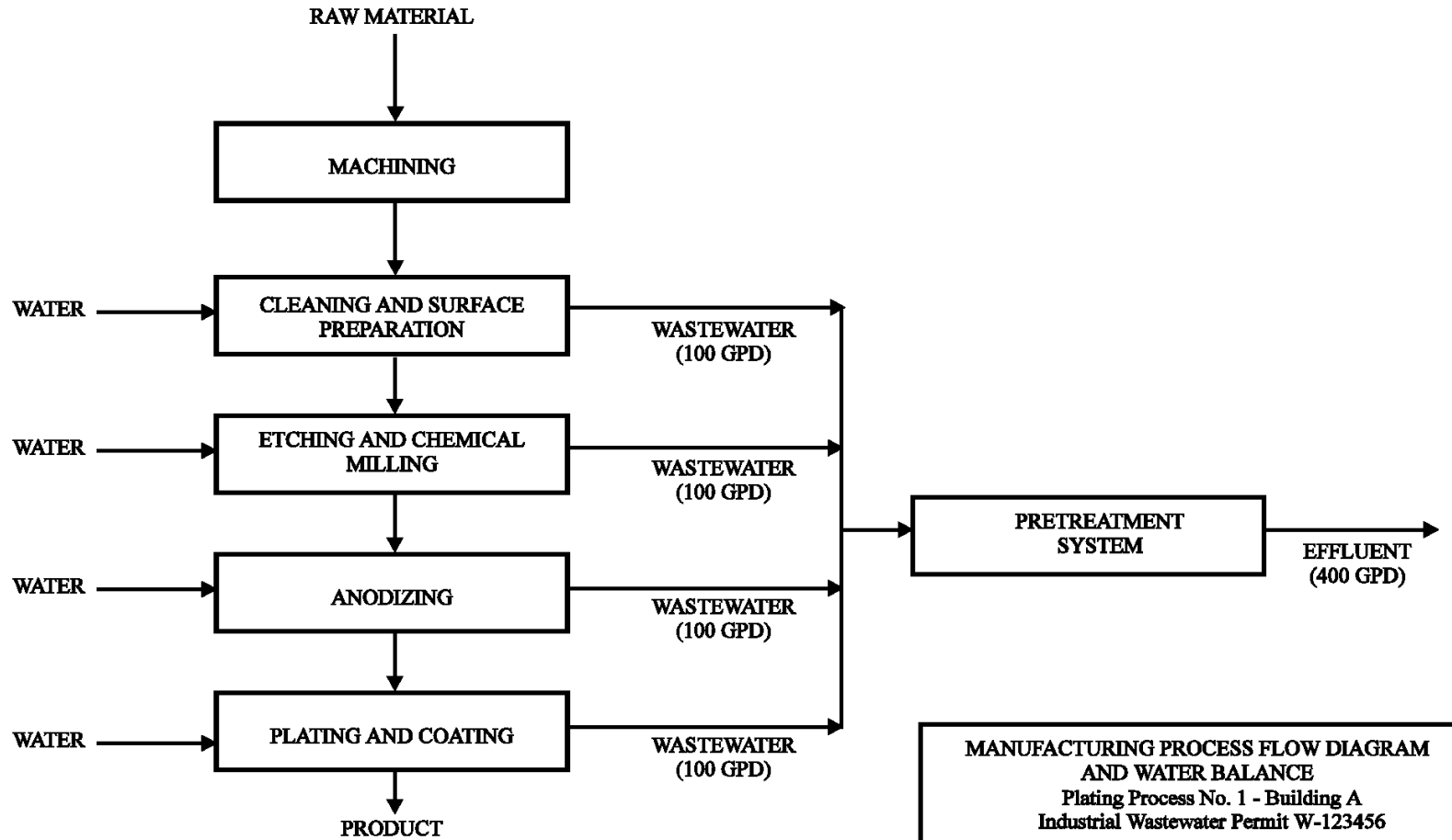

NOTE: GALLONS PER DAY (GPD)

TMFIG3.CDR

MANUFACTURING PROCESS FLOW DIAGRAM AND WATER BALANCE Plating Process No. 1 - Building A Industrial Wastewater Permit W-123456
XYZ COMPANY 12345 MAIN ST., EI SEGUNDO, CA. 90245
DRAWN BY: _____ DATE: _____ APPROVED BY: _____ DATE: _____