



## REQUEST FOR PROPOSALS



**ARCHITECTURAL DESIGN AND CONSULTANT SERVICES FOR THE  
URHO SAARI SWIM STADIUM  
RFP No. 20-02**

**City of El Segundo, Recreation & Parks Department,  
in coordination with the Public Works Department**

February 26, 2020

Dear Sir/Madam,

The City of El Segundo invites qualified consultants to submit a sealed proposal to provide architectural design services and consultant services related to the renovation and improvements of the Urho Saari Swim Stadium located at 219 W. Mariposa Avenue, El Segundo, CA 90245.

Five (5) hard copies and one (1) electronic copy of the sealed proposal are due to the City Clerk by:

**11:00 a.m. PST, March 24, 2020**

City of El Segundo  
350 Main Street Room No.5  
El Segundo, CA 90245

**Late proposal will not be accepted**

---

## **Section 1: Introduction, Background, and Project Description**

---

The City of El Segundo Department of Recreation and Parks is seeking the services of an architectural and consultant firm which specializes in Aquatic design, to assist the City of El Segundo with the renovation of the Urho Saari Swim Stadium. The architectural firm will report to the Recreation Superintendent, Arecia Hester. Any questions regarding this RFP may be emailed to [ahester@elsegundo.org](mailto:ahester@elsegundo.org) no later than Tuesday March 17, 2020 at 5:00 p.m.

The scope of professional services to be provided shall include the completion of the tasks described herein, as well as other elements or modifications which may be agreed upon through the request for proposal process. All services shall be provided in accordance with the City's standard Professional Services Agreement which is provided as Attachment B.

### **Background and History**

The Swim Stadium is named after a highly regarded swim coach who came to the area in 1941. Urho Saari coached Olympic water polo and swim teams. He quickly became an athletic aquatic legend in the City of El Segundo. The Urho Saari Swim Stadium is a beloved jewel to the residents of El Segundo. Originally built in 1940, the pool has 8 lanes and is 25 yards. There is also a separate small warm pool. Both pools operate on the same filtration system. Currently, the filtration, chlorination and mechanical systems are in need of an evaluation to determine their useful life as well as an analysis regarding potential ways to operate with more energy efficiency. The pool is programmed year-round, Monday-Friday 7a.m.-9pm, Saturday 6am-3:30pm and Sunday, 8am-12pm. The shallow end of the large pool is 4-feet and the deepest end of the pool is 12-feet. In the past swim teams and water polo teams have used the pool for practices, scrimmages and meets. Currently, two private water polo teams rent the space for practice and another private contractor rents the pool for a parent and me class. City programming includes recreation swim, lap swim, fitness classes and swim lessons. The City has one other outdoor year round facility (El Segundo Wiseburn Aquatic Facility) and one small outdoor seasonal facility (Hilltop Pool). Although a closure will impact programming, some displaced programming can be accommodated at the larger aquatic facility. An important part of this project will consist of engaging the community. The consultant will aim for providing design options that keep the original design of the pool as well as consider additional ideas which may enhance the visual appeal of the pool and allow for more variety in programming. (Attachment A: Site Plan)

---

## **Section 2: Scope of Services**

---

The selected consultant shall provide architectural design services for the Urho Saari Swim Stadium. The scope of the project is comprised of five tasks as follows:

### **Site Analysis**

In 2015, the City completed a study on The Plunge that identified the condition of the pool mechanical systems, the code requirements, and the financial analysis of renovating the pool and amenities. As part of the current scope of work, the selected consultant will review the previous studies and provide updated information on the current condition of the existing pools, mechanical equipment, support facilities including the locker rooms, entry and staff offices, and recommendations on ADA improvements. Consultant will review the site and equipment and determine the most efficient layout of the space and equipment within the given parameters.

### **Community Engagement**

This phase will involve meetings with City staff, community members, and stakeholder's for program development.

### **Needs Assessment**

Based on the input from the community engagement phase and the information discovered during the site analysis phase, the consultant will clearly define what the City's needs are for the facility, including refining the usage of space for more efficient layout of the facility. The consultant may also identify constraints that may be encountered during the design phase or potentially construction phase.

### **Schematic/Concept Design**

This schematics and concept designs will be prepared based on the results of needs assessment phase. The consultant will aim for providing design options that keep the original design of the pool as well as consider additional ideas which may enhance the visual appeal of the pool and allow for more variety in programming. Design flexibility of the space should be considered as an option.

This phase will advance the design of the project. The level of design will be consistent with current applicable standards (i.e. building code, health code, etc.) for preliminary approval and would provide sufficient detail for advancing the preliminary pricing and Environmental Impact Report (EIR) preparation (if needed). Consultant will advise the City on project impacts that are necessary for inclusion in an EIR and provide information on the historical impacts to the building, if any.

The recommended improvements and concept design are based on the site analysis, the results of the community engagement and the needs assessment of The Plunge.

### **Final Deliverables**

A final written report will be provided to the City which includes recommendations for the renovation. This report and concept design drawings are expected to be used as the basis for final design drawings.

In addition, the City also requests that the consultant provide suggested deliverables as part of this proposal. The consultant will define their approach to conducting this needs assessment and schematic / concept design and to advise the City on the recommended deliverables and approach for the project.

It is anticipated that the selected consultant will be utilized for Design Development and Construction Documents following the initial schematic design, however, this will depend on performance, additional contract approval, and is not guaranteed.

---

## **Section 3: Administration and Management**

---

The consultant will provide a detailed plan for project management, communication/coordination, and quality control to ensure successful and timely completion of the contract documents. The consultant shall submit progress reports with each monthly invoice. It is very important that the consultant strictly adheres to the schedule for the project and ensures timely completion. The work shall commence upon the issuance of a Notice to Proceed, anticipated to be on or about June 2020.

The consultant shall attend designated El Segundo Recreation and Parks Commission, El Segundo City Council and/or other public meetings through all phases of this project until final completion. For the purpose of the proposal, include adequate number of meetings with City staff (recreation and facilities) and with stakeholder's needed to complete the project.

---

#### **Section 4: Proposal**

---

The proposals, at a minimum, should include the following information:

- A. Cover Letter including the name of the main contact and their contact information including name, title, address, phone number and email address. Architectural firm should also indicate their willingness and ability to complete the Design Development and Construction Document phase of the project, should a design be selected and the City proceed with the project.
- B. Project Proposal including consultant's understanding of the project and a description of how the consultant will approach the project with specific milestones and deliverables as outlined in this RFP (Site Analysis, Community Engagement, Needs Assessment, Schematic/Concept Design, and Final Deliverables). Include with the proposal a sample of a schematic design from the architectural firm. Any issues and challenges that may be encountered shall be provided in this section.
- C. Qualifications demonstrating firm's expertise in successfully managing projects of this size and type as described, including work for municipal agencies. Include references.
- D. Personnel and Project Management including a list of key project staff and their qualifications, including sub-consultants, if any, to be retained by the consultant. Include an organization chart of the proposed project team. Include a statement committing the Project Manager and Lead designer to the entire project from start-up to completion, noting workload and availability.
- E. Scope of services to be provided with a breakdown of different tasks.
- F. Fee for Services including a fee breakdown by task. The fee shall be a not-to-exceed amount, including the estimated "other direct costs" such as mileage and reproduction. The Fee Proposal will include raw and loaded rates, noting overhead and profit percentages, and must be submitted with the proposal in a separate sealed envelope.
- G. Proposed schedule to provide the consultant services starting from the date of receipt of a Notice to Proceed from the City. The schedule should allow for review time for impacted agencies/parties.
- H. Statement of Acceptance that consultant is agreeable to execute the enclosed Professional Services Agreement (Attachment B: Sample Professional Services Agreement), to provide proof of insurance as noted in the agreement and to obtain and maintain a City Business License for the duration of the consultant services

---

#### **Section 5: Selection Process**

---

Consultant selection will be made by City staff based on content within the submittals with an emphasis on consultant's qualifications, project understanding, professional experience, community engagement plan, project deliverables, and ability to meet all aspects of the scope of work. The City will also evaluate based on results of reference checks, project schedule, and proposal fee and rate schedule.

The City reserves the right to select any consultant to complete the architectural design services described in this RFP and may elect to hold in-person interviews for final selection.

The Recreation and Parks department will make a recommendation to the City Council regarding the award of a contract based upon the department's evaluation. The City reserves the right to reject any or all proposals, in whole or part, to waive any informality in any proposal, and to accept the proposal which, in its discretion, is in the best interest of the City.

The successful consultant is selected by the City Council acting within its sole discretion. The City Council is under no obligation to contract with any consultant.

Proposals shall remain effective for sixty (60) days beyond the submittal deadline. All documents, drawings, and findings that are associated with this project shall be the property of the City of El Segundo.

To be considered, proposers must submit Five (5) copies and one (1) electronic copy of their proposal in a sealed envelope with the name and address of the company submitting the proposal and it should be clearly marked with the words **"Request for Proposal #20-02"** and the title **"Professional Architectural Design and Consulting Services / Urho Saari Swim Stadium Improvement Project"** no later than 11:00A.M. PST on March 24, 2020 to:

**Office of the City Clerk  
City of El Segundo  
350 Main Street Room No.5  
El Segundo, CA 90245-3813**

All submittals received after the scheduled submittal deadline will not be accepted and can be returned unopened at Proposer's expense.

If you need additional information, please contact me at 310-524-2702 or [AHester@elsegundo.org](mailto:AHester@elsegundo.org).

Sincerely,

Arecia Hester

Recreation Superintendent

### **Project Schedule**

The City reserves the right to make changes to the below schedule but plans to adhere to the implementation of this proposal process as follows:

<b><i>Project Schedule</i></b>	
February 26, 2020	RFP Release Date
March 3, 2020 @ 10:00am	Site Walk-Through – Not Mandatory – at Urho Saari Swim Stadium
March 17, 2020 @ 5:00pm	Deadline to Submit Questions
March 24, 2020 @ 11:00am	Proposals Due
March 26-April 10, 2020	City Review and Interviews of Qualified Consultants
April 13, 2020 (on or before)	Selection of Consultant
April 15, 2020	Presentation to Recreation and Park Commission
May 19, 2020	Presentation to Council
June 2020	Commence Project

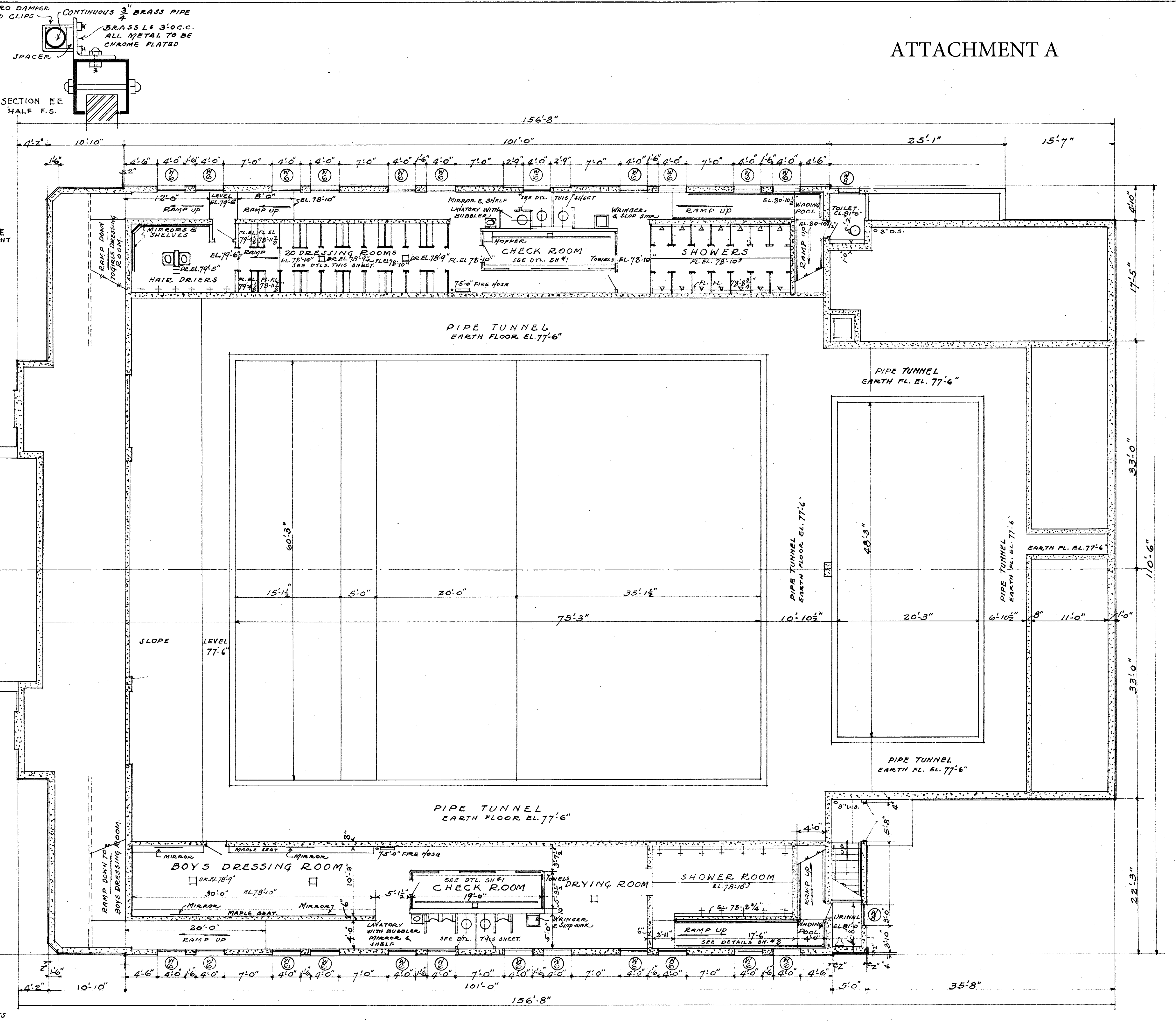
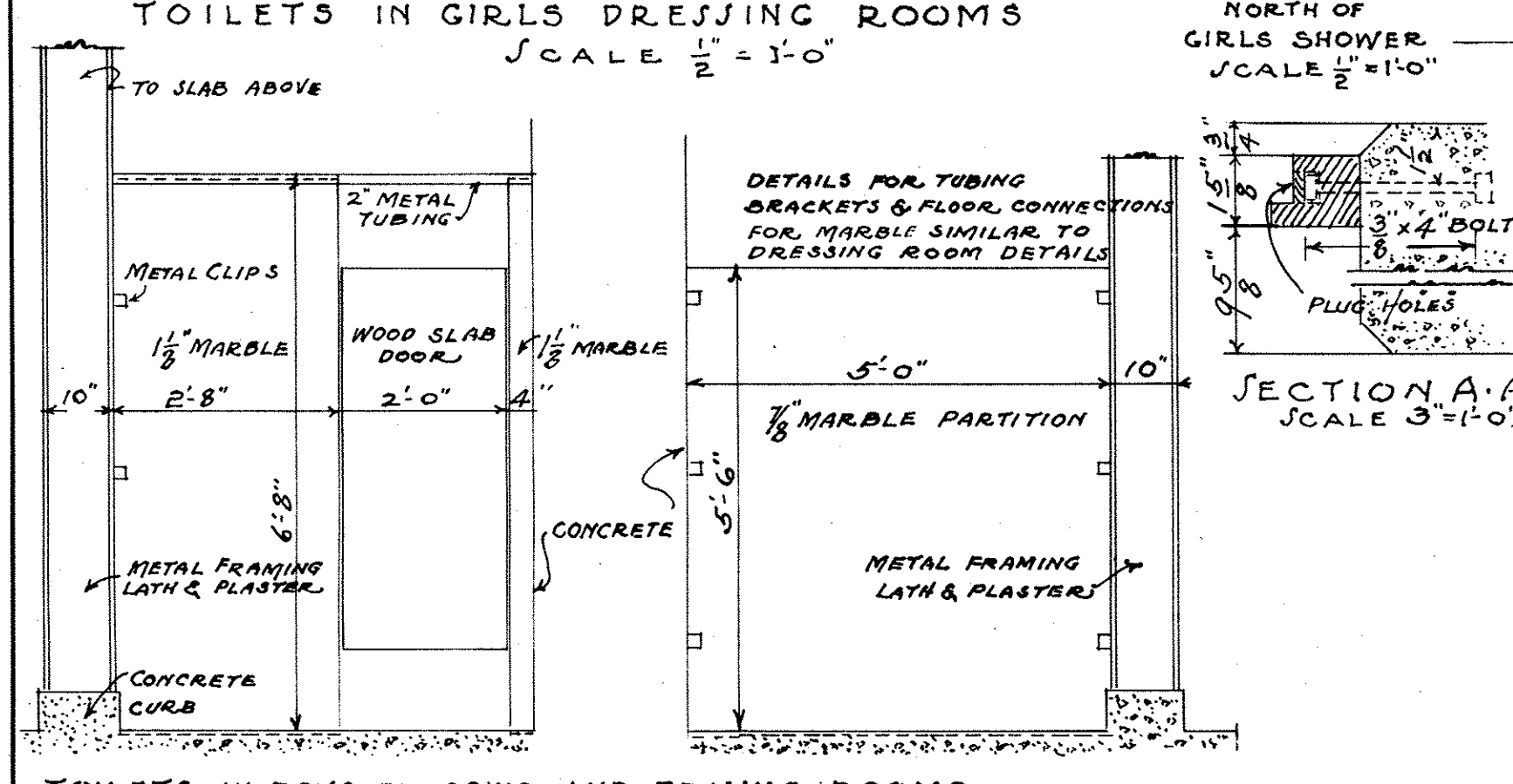
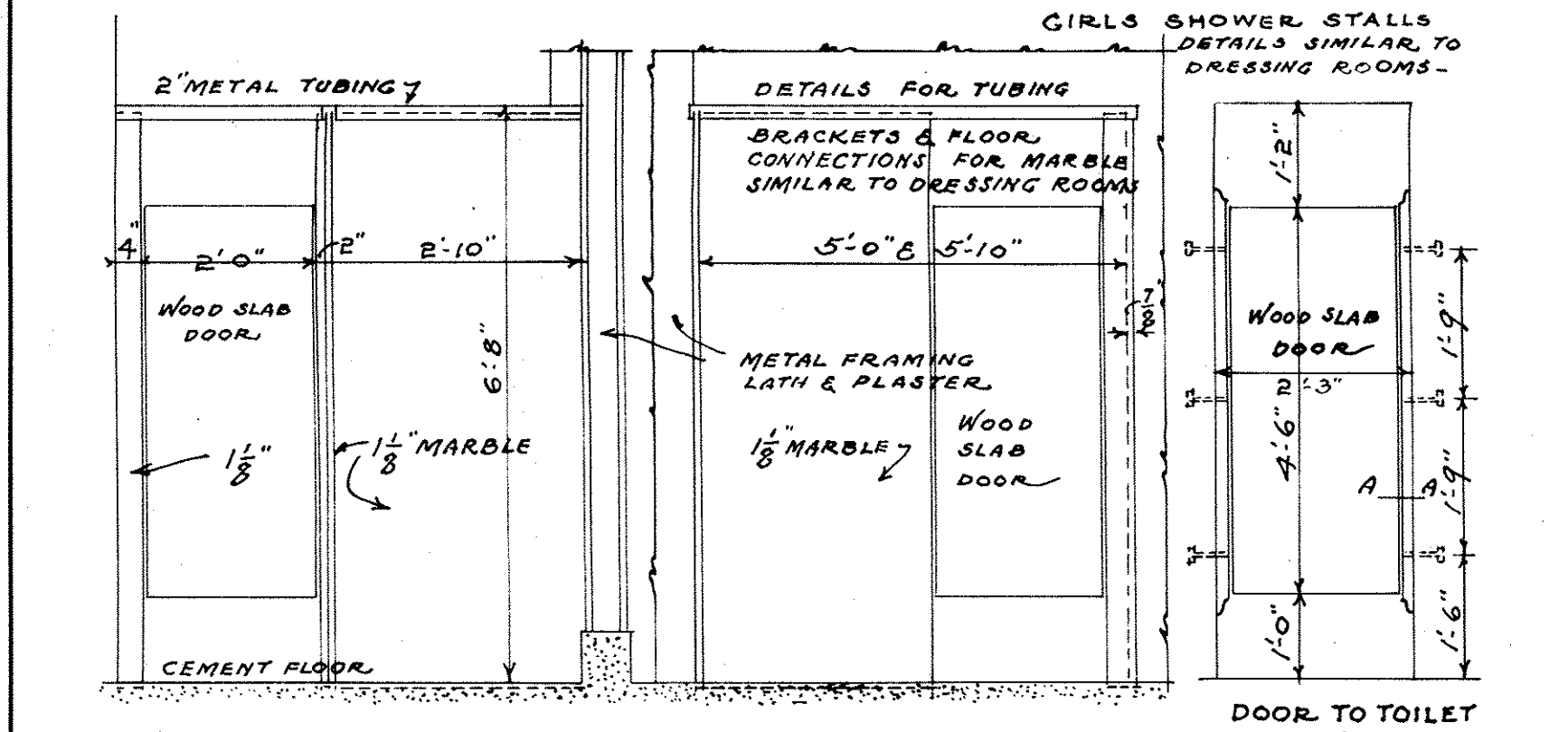
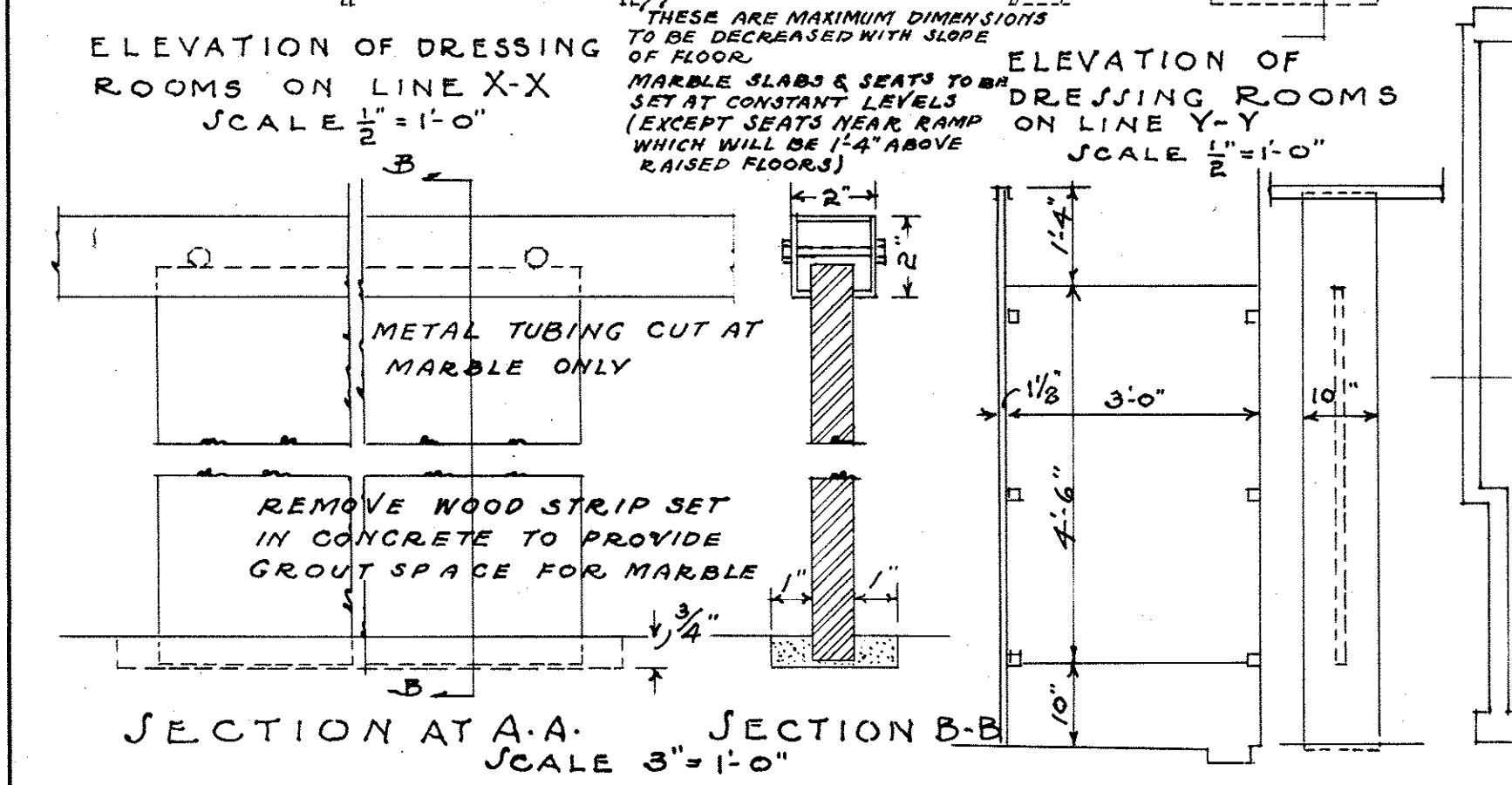
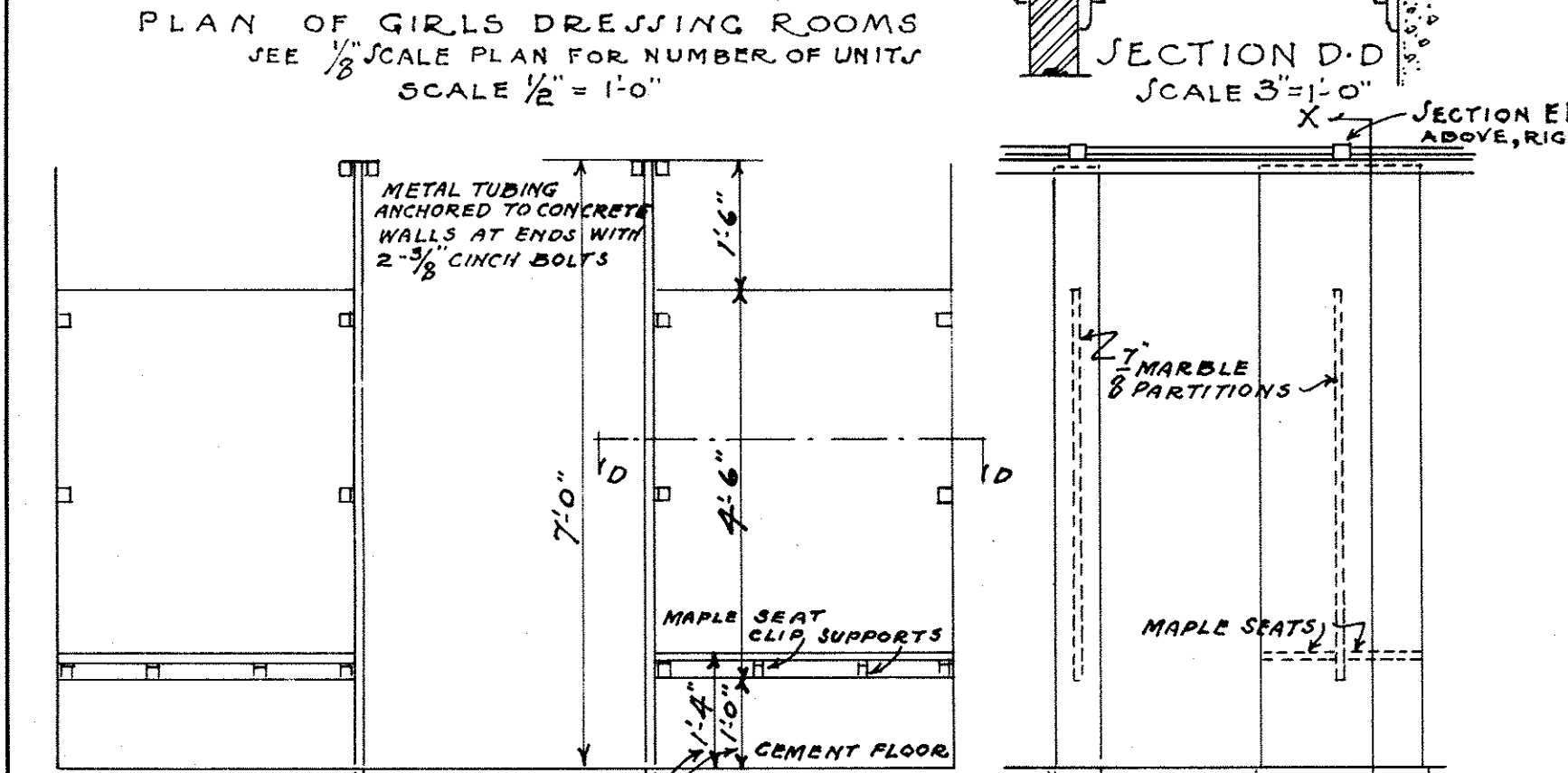
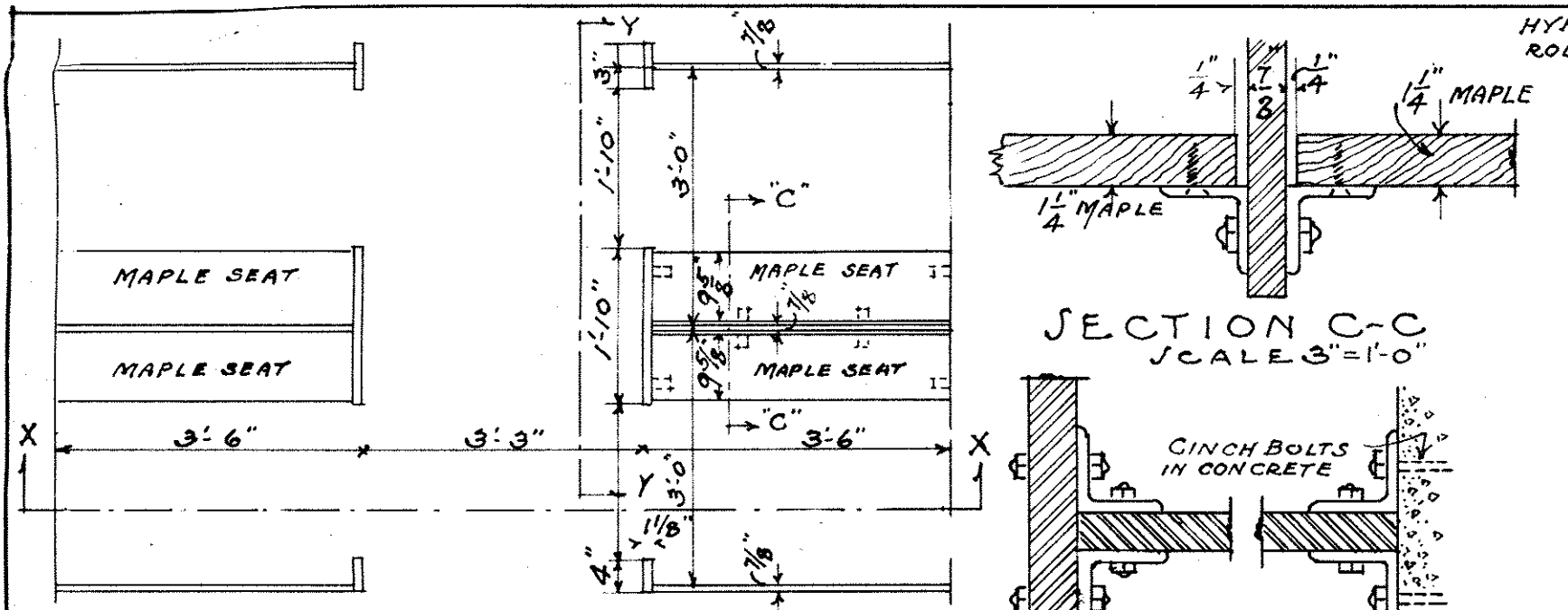

PLAN OF DRESSING ROOMS  
SCALE 1/8" = 1'-0"

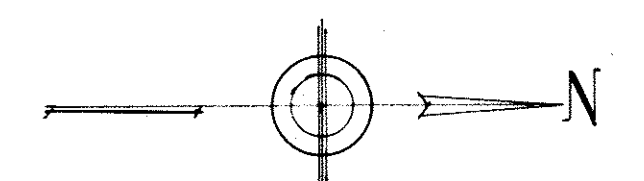

DRESSING ROOM PLAN	
PLUNGE EL SEQUENDO SCHOOL DISTRICT EL SEQUENDO, CALIFORNIA	
JOHN C. AUSTIN FAIA ARCHITECT	JOB 763
608 CHAMBER OF COMMERCE BLDG LOS ANGELES, CALIFORNIA	SHEET 2
DR. BY CAS. TR. FM. E.M.A. DATE NOV. 58	ARCHITECT

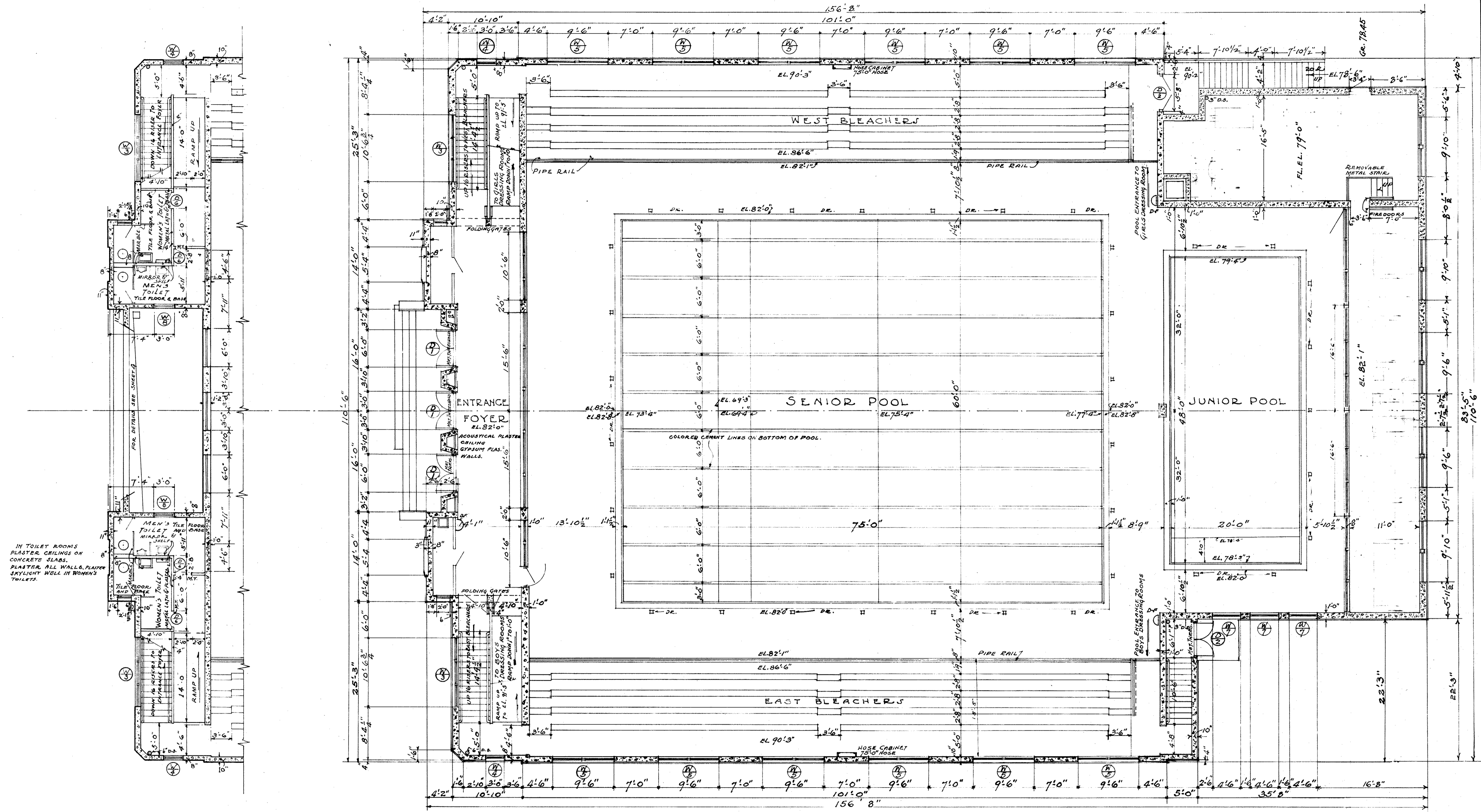

IN TOILET ROOMS  
PLASTER CEILINGS ON  
CONCRETE SLABS.  
PLASTER ALL WALLS, PLASTER  
SKYLIGHT WELLS IN WOMEN'S  
TOILETS.

PLAN OF TOILETS  
ABOVE ENTRANCE FOYER  
SCALE 1/8" = 1'-0"

BLEACHER & MAIN FLOOR PLAN  
SCALE 1/8" = 1'-0"

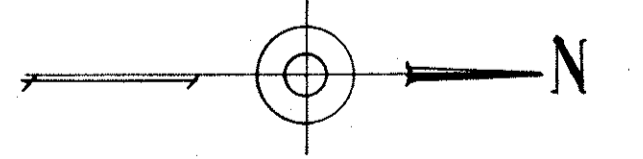

APPROVED DEPARTMENT OF EDUCATION	APPROVED DIVISION OF ARCHITECTURE	APPROVED BOARD OF TRUSTEES EL SEGUNDO SCHOOL DISTRICT	MAIN FLOOR PLAN PLUNGE EL SEGUNDO SCHOOL DISTRICT EL SEGUNDO CALIFORNIA
			JOHN C. AUSTIN F.A.I.A. ARCHITECT 608 CHAMBER OF COMMERCE BLDG LOS ANGELES CALIFORNIA
			DR. BY: <i>John C. Austin</i> ARCHITECT.
			JOB 768 SHEET 3 DATE NOV. 1938



**PROFESSIONAL SERVICES AGREEMENT  
FOR DESIGN SERVICES  
BETWEEN  
THE CITY OF EL SEGUNDO AND**

---

This AGREEMENT is entered into this \_\_\_ day of \_\_\_\_\_, 2020, by and between the CITY OF EL SEGUNDO, a municipal corporation and general law city ("CITY") and \_\_\_\_\_, a \_\_\_\_\_ corporation ("CONSULTANT"). The parties agree as follows:

**1. CONSIDERATION.**

- A. As partial consideration, CONSULTANT agrees to perform the work listed in the SCOPE OF SERVICES, below;
- B. As additional consideration, CONSULTANT and CITY agree to abide by the terms and conditions contained in this Agreement;
- C. As additional consideration, CITY agrees to pay CONSULTANT a sum not to exceed \_\_\_\_\_ for CONSULTANT's services. CITY may modify this amount as set forth below. Unless otherwise specified by written amendment to this Agreement, CITY will pay this sum as specified in the attached Exhibit "A," which is incorporated by reference.

**2. SCOPE OF SERVICES.**

- A. CONSULTANT will perform services listed in the attached Exhibit "A," which is incorporated by reference.
- B. CONSULTANT will, in a professional manner, furnish all of the labor, technical, administrative, professional and other personnel, all supplies and materials, equipment, printing, vehicles, transportation, office space and facilities, and all tests, testing and analyses, calculation, and all other means whatsoever, except as herein otherwise expressly specified to be furnished by CITY, necessary or proper to perform and complete the work and provide the professional services required of CONSULTANT by this Agreement.

**3. PERFORMANCE STANDARDS.** While performing this Agreement, CONSULTANT will use the appropriate generally accepted professional standards of practice existing at the time of performance utilized by persons engaged in providing similar services. CITY will continuously monitor CONSULTANT's services. CITY will notify CONSULTANT of any deficiencies and CONSULTANT will have fifteen (15) days after such notification to cure any shortcomings to CITY's satisfaction. Costs associated with curing the deficiencies will be borne by CONSULTANT.

**4. PAYMENTS.** For CITY to pay CONSULTANT as specified by this Agreement, CONSULTANT must submit a detailed invoice to CITY which lists the hours worked and hourly rates for each personnel category and reimbursable costs (all as set forth in Exhibit "A") the

## ATTACHMENT B

tasks performed, the percentage of the task completed during the billing period, the cumulative percentage completed for each task, the total cost of that work during the preceding billing month and a cumulative cash flow curve showing projected and actual expenditures versus time to date.

**5. NON-APPROPRIATION OF FUNDS.** Payments due and payable to CONSULTANT for current services are within the current budget and within an available, unexhausted and unencumbered appropriation of the CITY. In the event the CITY has not appropriated sufficient funds for payment of CONSULTANT services beyond the current fiscal year, this Agreement will cover only those costs incurred up to the conclusion of the current fiscal year.

**6. ADDITIONAL WORK.** N/A.

**7. FAMILIARITY WITH WORK.** By executing this Agreement, CONSULTANT agrees that it has:

- A. Carefully investigated and considered the scope of services to be performed;
- B. Carefully considered how the services should be performed; and
- C. Understands the facilities, difficulties, and restrictions attending performance of the services under this Agreement.

If services involve work upon any site, CONSULTANT agrees that CONSULTANT has or will investigate the site and is or will be fully acquainted with the conditions there existing, before commencing the services hereunder. Should CONSULTANT discover any latent or unknown conditions that may materially affect the performance of the services, CONSULTANT will immediately inform CITY of such fact and will not proceed except at CONSULTANT's own risk until written instructions are received from CITY.

**8. TERM.** The term of this Agreement will be from [REDACTED] to [REDACTED] [or for [REDACTED] years from [REDACTED]], unless otherwise terminated pursuant to Section 15.

**9. TIME FOR PERFORMANCE.**

- A. CONSULTANT will not perform any work under this Agreement until:
  - i. CONSULTANT furnishes proof of insurance as required under Section 23 of this Agreement; and
  - ii. CITY gives CONSULTANT a written notice to proceed.
- B. Should CONSULTANT begin work on any phase in advance of receiving written authorization to proceed, any such professional services are at CONSULTANT's own risk.

**10. CONSISTENCY.** In interpreting this Agreement and resolving any ambiguities, the main body of this Agreement takes precedence over the attached Exhibits; this Agreement supersedes any conflicting provisions. Any inconsistency between the Exhibits will be resolved in the order in which the Exhibits appear below:

- A. Exhibit A: **Quote.**

## ATTACHMENT B

B. Exhibit B:                     .

11. **CHANGES.** CITY may order changes in the services within the general scope of this Agreement, consisting of additions, deletions, or other revisions, and the contract sum and the contract time will be adjusted accordingly. All such changes must be authorized in writing, executed by CONSULTANT and CITY. The cost or credit to CITY resulting from changes in the services will be determined in accordance with written agreement between the parties.

12. **TAXPAYER IDENTIFICATION NUMBER.** CONSULTANT will provide CITY with a Taxpayer Identification Number.

13. **PERMITS AND LICENSES.** CONSULTANT, at its sole expense, will obtain and maintain during the term of this Agreement, all necessary permits, licenses, and certificates that may be required in connection with the performance of services under this Agreement.

14. **WAIVER.** CITY's review or acceptance of, or payment for, work product prepared by CONSULTANT under this Agreement will not be construed to operate as a waiver of any rights CITY may have under this Agreement or of any cause of action arising from CONSULTANT's performance. A waiver by CITY of any breach of any term, covenant, or condition contained in this Agreement will not be deemed to be a waiver of any subsequent breach of the same or any other term, covenant, or condition contained in this Agreement, whether of the same or different character.

### 15. **TERMINATION.**

- A. Except as otherwise provided, CITY may terminate this Agreement at any time with or without cause.
- B. CONSULTANT may terminate this Agreement at any time upon thirty days' written notice.
- C. Upon receiving a termination notice, CONSULTANT will immediately cease performance under this Agreement unless otherwise provided in the termination notice. Except as otherwise provided in the termination notice, any additional work performed by CONSULTANT after receiving a termination notice will be performed at CONSULTANT's own cost; CITY will not be obligated to compensate CONSULTANT for such work.
- D. Should termination occur, all finished or unfinished documents, data, studies, surveys, drawings, maps, reports and other materials prepared by CONSULTANT will, at CITY's option, become CITY's property, and CONSULTANT will receive just and equitable compensation for any work satisfactorily completed up to the effective date of notice of termination, not to exceed the total costs under Section 1(C).
- E. Should the Agreement be terminated pursuant to this Section, CITY may procure on its own terms services similar to those terminated.
- F. By executing this document, CONSULTANT waives any and all claims for damages that might otherwise arise from CITY's termination under this Section.

## ATTACHMENT B

**16. OWNERSHIP OF DOCUMENTS.** All documents, data, studies, drawings, maps, models, photographs and reports prepared by CONSULTANT under this Agreement are CITY's property. CONSULTANT may retain copies of said documents and materials as desired but will deliver all original materials to CITY upon CITY's written notice. CITY agrees that use of CONSULTANT's completed work product, for purposes other than identified in this Agreement, or use of incomplete work product, is at CITY's own risk.

**17. PUBLICATION OF DOCUMENTS.** Except as necessary for performance of service under this Agreement, no copies, sketches, or graphs of materials, including graphic art work, prepared pursuant to this Agreement, will be released by CONSULTANT to any other person or public CITY without CITY's prior written approval. All press releases, including graphic display information to be published in newspapers or magazines, will be approved and distributed solely by CITY, unless otherwise provided by written agreement between the parties.

**18. INDEMNIFICATION.** This Agreement contemplates that CONSULTANT will act both as a design professional (as defined by Civil Code § 2782.8) and for other management services. Accordingly, CONSULTANT agrees to provide indemnification as follows:

- A. **CONSULTANT must save harmless, indemnify and defend CITY and all its officers, employees and representatives from and against any and all suits, actions, or claims, of any character whatever, brought for, or on account of, any injuries or damages sustained by any person or property arising from, pertaining to, or relating to the negligence, recklessness, or willful misconduct of CONSULTANT or any of CONSULTANT's officers, agents, employees, or representatives.** CONSULTANT's duty to defend consists of reimbursement of defense costs incurred by CITY in direct proportion to the CONSULTANT's proportionate percentage of fault. CONSULTANT's percentage of fault will be determined, as applicable, by a court of law, jury or arbitrator. In the event any loss, liability or damage is incurred by way of settlement or resolution without a court, jury or arbitrator having made a determination of the CONSULTANT's percentage of fault, the parties agree to mediation to determine the CONSULTANT's proportionate percentage of fault for purposes of determining the amount of indemnity and defense cost reimbursement owed to the CITY; CONSULTANT and CITY must each pay half the mediator's fees. Notwithstanding the above, in the event one or more defendants to a Claim is unable to pay its share of defense costs due to bankruptcy or dissolution of the business, the CONSULTANT must meet and confer with the CITY regarding unpaid defense costs.
- B. *Defense For All Non-Design Professional Liabilities.* Notwithstanding the foregoing and without diminishing any rights of the CITY under subsection A, for any liability, claim, demand, allegation against CITY arising out of, related to, or pertaining to any act or omission of CONSULTANT, but which is not a design professional service, CONSULTANT must defend, indemnify, and hold harmless Indemnitees from and against any and all damages, costs, expenses (including reasonable attorneys' fees and expert witness fees), judgments, settlements, and/or arbitration awards, whether for personal or bodily injury, property damage, or economic injury, to the extent that they arise out of, pertain to, or relate to the negligence, recklessness, or willful misconduct of the CONSULTANT.
- C. For purposes of this section "CITY" includes CITY's officers, officials, employees,

ATTACHMENT B

agents, representatives, and certified volunteers.

- D. It is expressly understood and agreed that the foregoing provisions are intended to be as broad and inclusive as is permitted by the law of the State of California and will survive termination of this Agreement.

The insurance coverage to be maintained by CONSULTANT as required by Section 22, will not limit the liability of CONSULTANT hereunder. The provisions of this section will survive the expiration or earlier termination of this Agreement.

**19. ASSIGNABILITY.** This Agreement is for CONSULTANT’s professional services. CONSULTANT’s attempts to assign the benefits or burdens of this Agreement without CITY’s written approval are prohibited and will be null and void.

**20. INDEPENDENT CONTRACTOR.** CITY and CONSULTANT agree that CONSULTANT will act as an independent contractor and will have control of all work and the manner in which it is performed. CONSULTANT will be free to contract for similar service to be performed for other employers while under contract with CITY. CONSULTANT is not an agent or employee of CITY and is not entitled to participate in any pension plan, insurance, bonus or similar benefits CITY provides for its employees. Any provision in this Agreement that may appear to give CITY the right to direct CONSULTANT as to the details of doing the work or to exercise a measure of control over the work means that CONSULTANT will follow the direction of the CITY as to end results of the work only.

**21. AUDIT OF RECORDS.** CONSULTANT will maintain full and accurate records with respect to all services and matters covered under this Agreement. CITY will have free access at all reasonable times to such records, and the right to examine and audit the same and to make transcript therefrom, and to inspect all program data, documents, proceedings and activities. CONSULTANT will retain such financial and program service records for at least three (3) years after termination or final payment under this Agreement.

**22. INSURANCE.**

- A. Before commencing performance under this Agreement, and at all other times this Agreement is effective, CONSULTANT will procure and maintain the following types of insurance with coverage limits complying, at a minimum, with the limits set forth below:

<u>Type of Insurance</u>	<u>Limits</u>
Commercial general liability:	\$2,000,000
Professional Liability	\$1,000,000
Business automobile liability	\$1,000,000
Workers compensation	Statutory requirement

- B. Commercial general liability insurance will meet or exceed the requirements of ISO-CGL Form No. CG 00 01 11 85 or 88, or equivalent. The amount of insurance set forth above will be a combined single limit per occurrence for bodily

ATTACHMENT B

injury, personal injury, and property damage for the policy coverage. Liability policies will be endorsed to name CITY, its officials, and employees as “additional insureds” under said insurance coverage and to state that such insurance will be deemed “primary” such that any other insurance that may be carried by CITY will be excess thereto. CITY’s additional insured status will apply with respect to liability and defense of suits arising out of CONSULTANT’s acts or omissions. Such insurance will be on an “occurrence,” not a “claims made,” basis and will not be cancelable or subject to reduction except upon thirty (30) days prior written notice to CITY.

- C. Professional liability coverage will be on an “occurrence basis” if such coverage is available, or on a “claims made” basis if not available. When coverage is provided on a “claims made basis,” CONSULTANT will continue to renew the insurance for a period of three (3) years after this Agreement expires or is terminated. Such insurance will have the same coverage and limits as the policy that was in effect during the term of this Agreement and will cover CONSULTANT for all claims made by CITY arising out of any errors or omissions of CONSULTANT, or its officers, employees or agents during the time this Agreement was in effect.
- D. Automobile coverage will be written on ISO Business Auto Coverage Form CA 00 01 06 92, including symbol 1 (Any Auto).
- E. CONSULTANT will furnish to CITY valid Certificates of Insurance evidencing maintenance of the insurance required under this Agreement, a copy of an Additional Insured endorsement confirming CITY has been given Insured status under the CONSULTANT’s General Liability policy, and such other evidence of insurance or copies of policies as may be reasonably required by CITY from time to time. Insurance must be placed with insurers with a current A.M. Best Company Rating equivalent to at least a Rating of “A:VII.”
- F. Should CONSULTANT, for any reason, fail to obtain and maintain the insurance required by this Agreement, CITY may obtain such coverage at CONSULTANT’s expense and deduct the cost of such insurance from payments due to CONSULTANT under this Agreement or terminate pursuant to Section 15.

**23. USE OF SUBCONTRACTORS.** CONSULTANT must obtain CITY’s prior written approval to use any consultants while performing any portion of this Agreement. Such approval must approve of the proposed consultant and the terms of compensation.

**24. INCIDENTAL TASKS.** CONSULTANT will meet with CITY monthly to provide the status on the project, which will include a schedule update and a short narrative description of progress during the past month for each major task, a description of the work remaining and a description of the work to be done before the next schedule update.

**25. NOTICES.** All communications to either party by the other party will be deemed made when received by such party at its respective name and address as follows:

If to CONSULTANT:

If to CITY:

Address

City of El Segundo

ATTACHMENT B

Address  
Phone  
Attention: Name

350 Main Street  
El Segundo, Calif. 90245  
Attention:

Any such written communications by mail will be conclusively deemed to have been received by the addressee upon deposit thereof in the United States Mail, postage prepaid and properly addressed as noted above. In all other instances, notices will be deemed given at the time of actual delivery. Changes may be made in the names or addresses of persons to whom notices are to be given by giving notice in the manner prescribed in this paragraph.

**26. CONFLICT OF INTEREST.** CONSULTANT will comply with all conflict of interest laws and regulations including, without limitation, CITY's conflict of interest regulations.

**27. SOLICITATION.** CONSULTANT warrants that it has not employed nor retained any company or person, other than CONSULTANT's bona fide employee, to solicit or secure this Agreement. Further, CONSULTANT warrants that it has not paid nor has it agreed to pay any company or person, other than CONSULTANT's bona fide employee, any fee, commission, percentage, brokerage fee, gift or other consideration contingent upon or resulting from the award or making of this Agreement. Should CONSULTANT breach or violate this warranty, CITY may rescind this Agreement without liability.

**28. THIRD PARTY BENEFICIARIES.** This Agreement and every provision herein is generally for the exclusive benefit of CONSULTANT and CITY and not for the benefit of any other party. There will be no incidental or other beneficiaries of any of CONSULTANT's or CITY's obligations under this Agreement.

**29. INTERPRETATION.** This Agreement was drafted in and will be construed in accordance with the laws of the State of California, and exclusive venue for any action involving this agreement will be in Los Angeles County.

**30. COMPLIANCE WITH LAW.** CONSULTANT agrees to comply with all federal, state, and local laws applicable to this Agreement.

**31. ENTIRE AGREEMENT.** This Agreement, and its Exhibits, sets forth the entire understanding of the parties. There are no other understandings, terms or other agreements expressed or implied, oral or written. There are [redacted] Exhibits to this Agreement. This Agreement will bind and inure to the benefit of the parties to this Agreement and any subsequent successors and assigns.

**32. RULES OF CONSTRUCTION.** Each Party had the opportunity to independently review this Agreement with legal counsel. Accordingly, this Agreement will be construed simply, as a whole, and in accordance with its fair meaning; it will not be interpreted strictly for or against either Party.

**33. SEVERABILITY.** If any portion of this Agreement is declared by a court of competent jurisdiction to be invalid or unenforceable, then such portion will be deemed modified to the extent necessary in the opinion of the court to render such portion enforceable and, as so modified, such portion and the balance of this Agreement will continue in full force and effect.

**34. AUTHORITY/MODIFICATION.** The Parties represent and warrant that all necessary action has been taken by the Parties to authorize the undersigned to execute this Agreement and to

## ATTACHMENT B

engage in the actions described herein. This Agreement may be modified by written amendment. CITY's executive manager, or designee, may execute any such amendment on behalf of CITY.

**35. ACCEPTANCE OF ELECTRONIC SIGNATURES.** The Parties agree that this Agreement, agreements ancillary to this Agreement, and related documents to be entered into in connection with this Agreement will be considered signed when the signature of a party is delivered by electronic (.pdf) or facsimile transmission. Such electronic or facsimile signature will be treated in all respects as having the same effect as an original signature.

**36. CAPTIONS.** The captions of the paragraphs of this Agreement are for convenience of reference only and will not affect the interpretation of this Agreement.

**37. TIME IS OF ESSENCE.** Time is of the essence for each and every provision of this Agreement.

**38. FORCE MAJEURE.** Should performance of this Agreement be prevented due to fire, flood, explosion, acts of terrorism, war, embargo, government action, civil or military authority, the natural elements, or other similar causes beyond the Parties' reasonable control, then the Agreement will immediately terminate without obligation of either party to the other.

**39. STATEMENT OF EXPERIENCE.** By executing this Agreement, CONSULTANT represents that it has demonstrated trustworthiness and possesses the quality, fitness and capacity to perform the Agreement in a manner satisfactory to CITY. CONSULTANT represents that its financial resources, surety and insurance experience, service experience, completion ability, personnel, current workload, experience in dealing with private consultants, and experience in dealing with public agencies all suggest that CONSULTANT is capable of performing the proposed contract and has a demonstrated capacity to deal fairly and effectively with and to satisfy a public CITY.

[Signatures on next page]

ATTACHMENT B

IN WITNESS WHEREOF the parties hereto have executed this Agreement the day and year first hereinabove written.

CITY OF EL SEGUNDO

NAME

\_\_\_\_\_  
Scott Mitnick,  
City Manager

\_\_\_\_\_  
By:  
Its:

\_\_\_\_\_  
By:  
Its:

ATTEST:

\_\_\_\_\_  
Tracy Weaver,  
City Clerk

Taxpayer ID No. \_\_\_\_\_

APPROVED AS TO FORM:

\_\_\_\_\_  
Mark D. Hensley,  
City Attorney

Insurance Approved by: \_\_\_\_\_